



GRAN VIOLA SIGNATURE (active) Manual

1. Thanks

We thank you for having chosen the WLM reference loudspeaker **GRAN VIOLA SIGNATURE** and the confidence you have thus proven in our product.

Due to the new functioning of the WLM speakers we are asking you to read this manual carefully before connecting or operating your speakers. Your benefits: an optimized installation will lead to an improved sound reproduction.

2. Supply

The supply of the GRAN VIOLA loudspeakers comprises:

- 2 GRAN VIOLA - speakers
- 2 x 4 Spikes
- 1 aiming gauge (for the positioning of the left/right speakers)
- This manual
- Warranty Registration Form

Note: the Spikes and the aiming device are either placed in the bass reflex tube (bottom of the speakers) or as a separate pack in one of the main boxes.

The **packaging** of the cabinets provides a perfect protection to our product during transportation. We recommend to keep it for future shipping needs.

IMPORTANT NOTICE: The model GRAN VIOLA - active is *not* equipped with a built-in filter and can therefore *not* be operated in the "passive" mode; an external, active filter module is required between the pre-amp and the amp(s) feeding the split signals to the speaker.

3. Description

The GRAN VIOLA can be operated as a full range speaker reproducing the high as well as the medium/low frequencies (e.g. via the active SYSTEM CONTROL module), or in combination with a subwoofer (e.g. WLM DUO) as a speaker for the high and medium frequencies only (again with SYSTEM CONTROL as the external filter module).

In both cases the GRAN VIOLA is to be connected to the corresponding amps separately for high and medium/bass or for high and just medium.

The solid WBT connector terminals for bi-wiring accept all known loudspeaker cable ends: bare cables, banana or forked cable shoes.

It is up to your personal preference whether you want to operate your speakers with or without its front covers. They have little or no effect on the quality of the sound reproduction.

Please keep in mind that the speakers have a bass reflex opening below in the cabinet. It is vital that the sound waves coming from this aperture should "radiate" freely to all sides. The spikes supplied are an ideal means the keep an appropriate gap between the floor and the speaker cabinets.

The spikes supplied are also a goods means for the firm placement of the speaker cabinets on the ground; their purpose is also to decouple the speaker from the support.

Screw the spikes in the sockets inserted in the bottom of the cabinets. We recommend to tighten the counter screws after having adjusted the cabinets vertically "plumb". Each speaker should rest solidly on the 4 spikes. Vibrating or even wobbling would hamper the sound reproduction considerably.

4. Positioning of the Speakers

The unique WLM SUPER PAC technology will be put to maximum effect only when the following rules and guidelines are observed.

The pair of speakers consist of a **LEFT** and **RIGHT** box (seen from the listener's position); they differ one from another and should not be switched by mistake. At the rear terminal the boxes are marked "*L left*" and "*R right*".

The distance between the boxes themselves should be 1.5 times the distance of the boxes to the listener's place.

Example: supposing that the listener is 3.0 m away from the boxes, and then the distance between the boxes should be 4.5 m.

For the purpose of a perfect sound stage, the distance behind the boxes to the rear wall should be at least 1.0 m, preferably more. The distance to the side wall should be considerably less than that (>0.25 m).

Thanks to the WLM SUPER PAC Technology (more about this below) the clearly noticeable sound stage will built up between the speakers, quite similar to a large blister.

For the final and precise positioning of boxes, the aiming device supplied should be employed without fail. Place this device on top of the cabinets (right on the tweeter assembly) and change its inner gauge block left/right as marked. The marked front edge of the aiming device (gauge block with aiming wedge and main unit) should face the listener as shown in the drawing below. The boxes are in the right position when the respective gauge lines are pointing directly at the listener.

4.1 SUPER PAC – Speaker aiming device

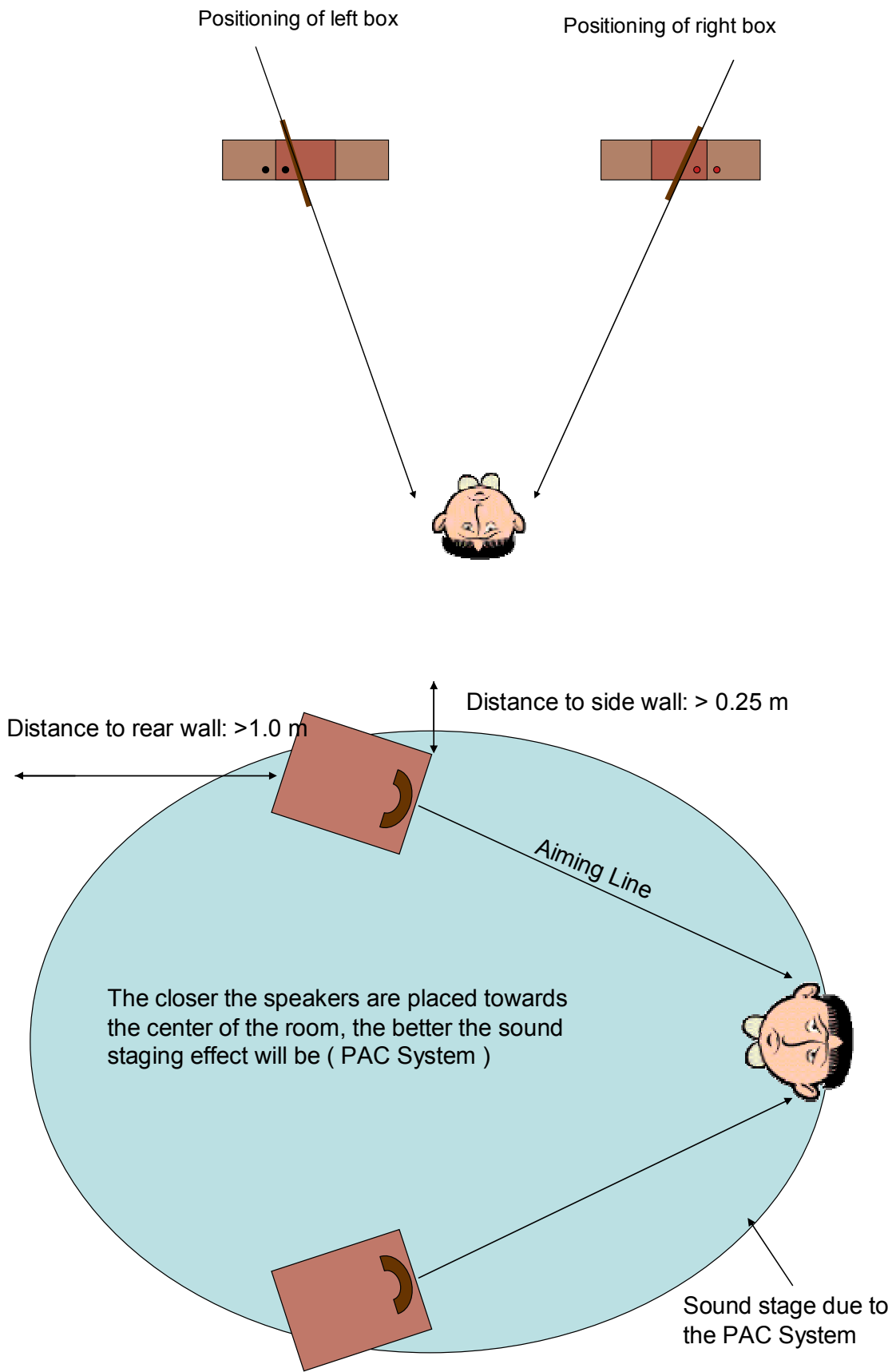

5. Connections in the various operation modes

5.1 Introduction to the Active Operation Mode

The **active** GRAN VIOLA speaker is to be operated exclusively in the **active** mode. The speakers themselves do not have a ("passive") built-in filter which would split the signal into the high and medium/low or just medium portions. This job is given to an external filter module; it will "prepare" the signal coming from the pre-amp for the subsequent amplification and feeding to the corresponding drivers of the speaker (separate for each frequency range). SYSTEM CONTROL (SC) as active, external filter module will enable you to set specific volume levels of the frequency ranges and to adjust their sound reproduction individually to suit the prevailing room acoustics (see the manual of the SYSTEM CONTROL).

5.2 Operation as full-range speaker

In this mode, the GRAN VIOLA is reproducing the full signal. The signal (coming from the pre-amp) will be split into the two frequency ranges (as described above) and thereafter amplified separately: high and medium/low frequency ranges. The split is done at about 1000 Hz.

The amps are connected to the GRAN VIOLA by the speaker cables attached to +/- poles at both ends: high frequencies to the upper pair of connectors at the speaker terminal, medium/low to the lower connectors of the GRAN VIOLA.

The following illustration shows the connection scheme. Please make sure that each cable is connected correctly either to red (+) or black/white (-) at the amps and the speakers.

5.3 Illustration of the full-range connection

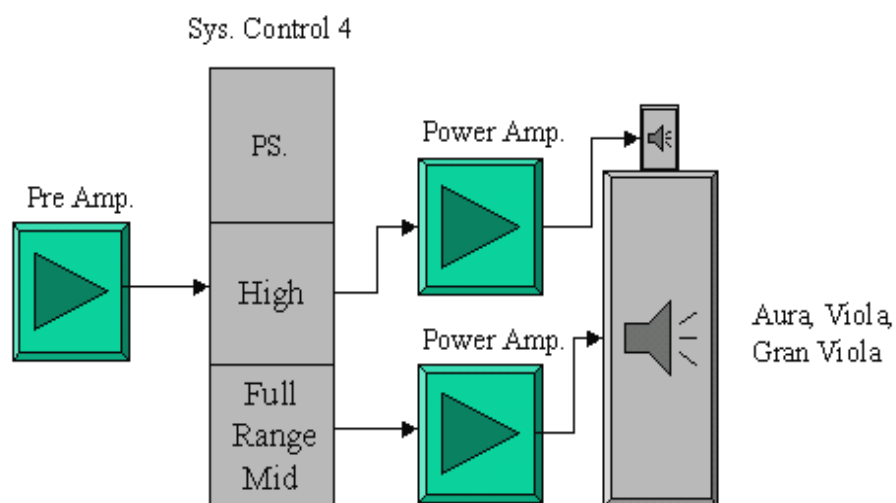

5.3 Operation as active speaker for high and medium frequencies only

(in combination with a separate DUO Sub-Woofer)

In this mode, the signal coming from the pre-amp is split in *three* frequency ranges: high and medium frequencies (for the main speaker) and low frequencies (for the subwoofer). The split frequencies in this mode are 80/90 Hz and 1000 Hz.

For the connection of the GRAN VIOLA you proceed in a similar way as described above; however, in this mode you will have to handle three frequency outputs (instead of two before) supplied by the SYSTEM CONTROL.

You now need three amps instead of two: for the high, the medium and the low frequencies.

The following illustration shows the connection scheme in this mode.

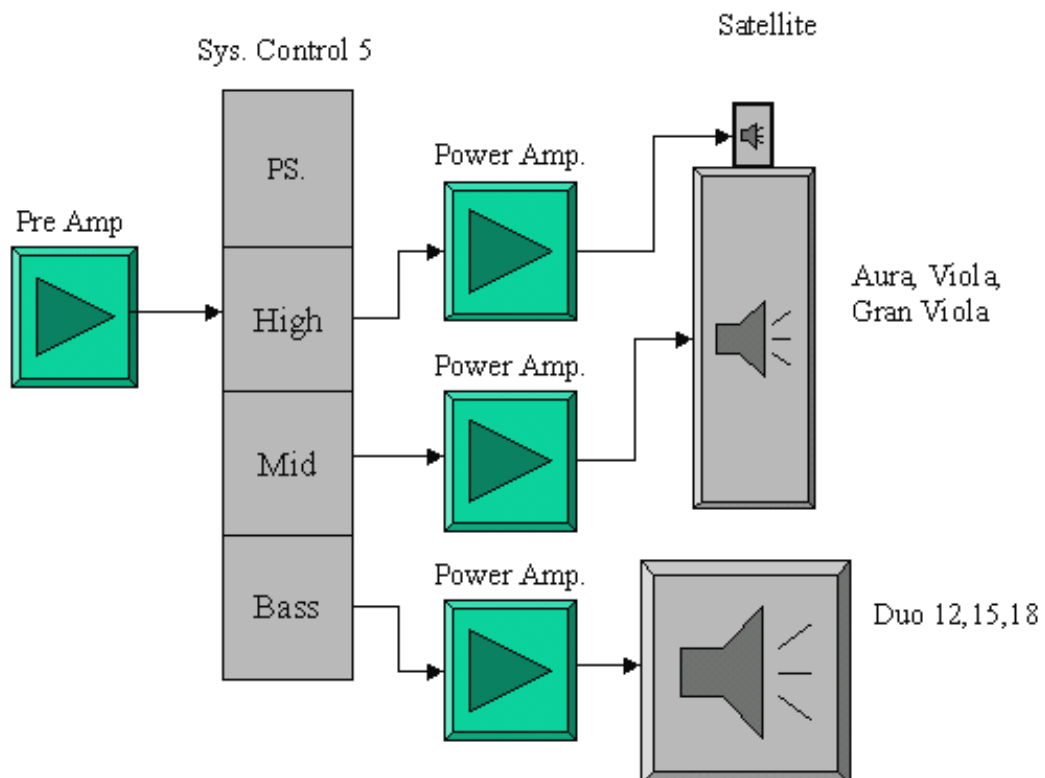

Since *one* subwoofer in most cases is adequate to reproduce the bass portion of a signal, you then have to make sure that the subwoofer will get the proper signal portions of both channels. The single twin speaker cable is to be connected as follows: the + pole of the right channel of the amp to the + pole (red) of the subwoofer, the + pole of the left channel of the amp to - pole (black or white) of the subwoofer. By following this scheme, main speaker and subwoofer will be "in phase".

Should standing waves nevertheless build up at the place of the listener then we suggest the following alternative corrections:

- Switch connections at the subwoofer
- Change location of the subwoofer
- Try a different correction adjustment at the SYSTEM CONTROL

6. Technical Explanations

Speaker Efficiency

The efficiency of a speaker system, measured in sound pressure (dB at 1W, at a distance of 1 m), specifies its effectiveness of reproducing a given signal. The higher the efficiency, the lower the demand regarding the performance of an amplifier and the efforts required to reach higher volume levels.

WLM speakers excel in this respect, since they offer an exceptional and unusual efficiency of 98 dB (1W, 1m).

6.2 Impulse Behavior

The faster and the more precise a speaker responds to the changes of a signal impulse (by swinging the membrane forward and backward), the better the sound impression will be. The smallest delays between the reception of the impulse and its transformation (initiation of the membrane movement and its stop) will have a distinct impact on the quality of the sound reproduced and perceived.

The specially hard support of the paper membranes on one side and the extremely strong, high performance magnet coils on the other side are warrants for an extraordinary impulse behavior of all WLM speaker systems.

6.5 SUPER PAC ("*Phase Acoustic Corrected*")

PAC stands for a special and unique advantage of the WLM speakers; i.e. the capability of reproducing an almost perfect sound stage in 3-dimensional extension with 2 speakers.

To understand this concept we have to explain that lower frequencies alone do not lend themselves and are therefore not vital for the stage building process during the sound reproduction. Only with higher frequencies stage building (and perception) is possible. Therefore, to reproduce a given signal in a space-like manner it is important that it contains medium and high frequencies together with the lower frequency waves.

The prevailing sounds in our surrounding world, usually deriving from single sources, consist of a mix of different frequencies and are discerned and located readily in a given space context. On the other hand, our ears have to accomplish the difficult task to amalgamate the sounds reproduced "artificially" by 2 separate loudspeakers via special drivers for high and medium/low frequencies to a full space-like entity.

Speakers having conventional tweeter concepts in a variety of techniques are fighting with the difficulty to fuse the higher and lower frequencies deriving from the 2 stereo speakers for space-like perception.

The high frequency waves conventionally emitted in front direction do not merge with the medium and low frequency waves coming from the same speaker and also not with the high frequencies portions coming from the tweeter of the other (stereo) speaker. The listener's ear can not be betrayed, he will hear the speakers rather than the music in its appropriate spacious extension. In addition, the higher frequencies are traveling so much faster to our ears than the medium or lower signal portions. This will result in disturbing time lags over the entire frequency range, overemphasizing the distinct 2-channel reflection of sound, also destroying any chance of a natural, space-like perception of the music reproduced.

The special execution and positioning of the tweeter system of the WLM speakers is enabling first the homogenous merging of the high frequencies emerging from the 2 juxtaposed speakers and then also the merging with the medium and low frequencies of a given signal coming from different drivers. The WLM listener is able to hear a distinctly structured sound stage image. No longer is he limited and fixed to a narrowing 2-channel reproduction of his speakers. In the listener's acoustic perception the WLM-PAC speakers will actually disappear in the background. He will experience the rare and rewarding feeling of being put right in the middle of the recording atmosphere.

The world unique SUPER PAC technology is granting for the first time an almost perfect space-like imaging of recorded music from 2 loudspeakers only.

Specification: GAN VIOLA SIGNATURE active

Drivers	SUPER PAC Tweeter-System 10" paper cone chassis
Impedance	8 Ohm
Frequency Response	25 Hz to 25kHz
Sensitivity	98 dB - 1m/1W
Recommended Amplifier Power	3,5 to 250 Watt
Wiring Methods	Bi-Wiring
Dimensions	50,80" (1290 mm) high (incl. Spikes) 10,43" (265 mm) wide 13,00" (330 mm) deep
Weight	72,28 LB (33 Kg) each

8. Warranty

Limited Warranty

During the warranty period the *Wiener Lautsprecher Manufaktur* will guarantee that their products are free of flaws and well functioning

The warranty periods for the various products are: Loudspeaker GRAN VIOLA - 5 years, SYSTEM CONTROL - 2 years (counted from the date of purchase at an authorized WLM-Dealer).

Condition for the warranty service is that the products are operated in accordance with this manual.

During the warranty period WLM will replace or repair the defect parts free of charge to the customer. Condition is however:

- The warranty registration card is received by WLM within 30 days after the date of purchase.
- The cabinets are not showing any traces of physical damage and inside there are no signs of overheating due to wrong installation/operation resulting in an overloading of certain parts.
- The PCBs and components thereof are not showing any signs of undue handling, regardless whether the intention was to repair or to modify the unit under claim
- There is no indication what-so-ever that the WLM products have been operated differently as specified by the manual..

In addition, the customer will loose his right for a warranty claim when the serial-Nr. of the unit in question has been modified, removed or manipulated in any way. WLM will not be held responsible for damages resulting from repairs executed by un-authorized personnel.

Collateral Damage

During the duration of this limited warranty period (and there-after) WLM will not be responsible for collateral damage, directly or indirectly linked to the operation of the WLM product.

Warranty claim

The customer may on the basis of this limited warranty claim the repair or replacement of the defective part by the manufacturer or the authorized dealer with no charge to him. For the claim please contact either WLM directly or the WLM distributor in your country. After receipt of the claim confirmation please send the unit under claim to the shown address. The defect will be examined and, when justified, will be repaired at no cost to the customer. The customer will have to bear the cost of shipment. Without a corresponding warranty claim (received within 30 days after the date of purchase at the address below) no warranty claim will be accepted or processed.

WLM Loudspeakers

Treietstrasse 56

A-6832 Sulz

AUSTRIA

Phone: +43 (0)5522 44641 (Customer Service)

Web: www.wlm-loudspeakers.com



Loudspeakers

Warranty Registration

Please ask your dealer to fill in this form at the time of the purchase.

This registration will entitle you to call on WLM for technical support and it is a prerequisite for an eventual warranty claim against WLM.

Please send your registration to:

WLM Loudspeakers
Treietstrasse 56
A-6832 Sulz
Austria

Customer Service:

Phone : +43 (0)5522 44641

Fax : +43 (0)5522 44641-74

Web : www.wlm-loudspeakers.com

Unit/Model: **GRAN VIOLA SIGN. active** Serial-Nr.:.....

Unit/Model:..... Serial-Nr.:.....

Unit/Model:..... Serial-Nr.:.....

Date of Purchase:.....Dealer Name:.....

Dealer Address:.....

First/last name of customer:

Address Street:

Postal Code/Town:

Customer Contact Phone:

Fax:

E-Mail:

Your comments are always appreciated: